



Safe Driving Assistance with Road Communication using Zigbee

Ms. Garud Rupali G.¹, Mr. Kale Anklet V.²

Student, BE, Electronic and Telecommunication, DACOE, Karad, India¹

Asst. Professor Electronic and Telecommunication, DACOE, Karad, India²

Abstract: Today there are various sign indications available on roadside but the driver many times unable to see information due to person mistake and bad climate condition. Nowadays there are new technologies integrated in one system which makes a complex solution and much expensive. So to overcome the above problems we introduced the safe driving assistance with road communication using zigbee technology.

Keywords: Driver Assistance Systems, Vehicular Communication, Zigbee Protocol.

I. INTRODUCTION

Current days we are using various technology such as radar, GPS, sensors. Combining all of these technology into single system become complex system which refers to high power consumption, low battery life, high cost, complexity etc.

To overcome the above problem the solution seeks the new technology which introduces the zigbee. Nowadays vehicle to vehicle, vehicle to road, vehicle to environment has become the need in order to make road safer, cleaner and to manage the traffic, to reduce the road accidents [1].

While today's vehicle are already able to sense the surrounding environment, we expect that future car will communicate with roadside communication infrastructure and with each other. [2]

Here in this system we use zigbee network. Zigbee is transceiver and is only standard based wireless technology designed to address the unique needs of low cost, low power wireless sensor and control networks.[1]

Due to the advantageous nature of zigbee we used it in driver assistance system that is it provides the information from the preset waypoint to car system about any roadside infrastructure [signboards, drive in restaurant]. Zigbee can be used with combination of RF and ultrasound for indication and for cost benefit. [5]

Here we will place the portable unit in the car and a waypoint unit at a preset point. The waypoint unit will provide the information to the portable unit of any sign indication.

So whenever the information is needed such information is automatically passed on to the portable unit from waypoint unit and the driver in the car can get a clear idea of the contents received.

TABLE I. FEATURES OF ZIGBEE[1]

Feature	Wi-Fi	Bluetooth	Zigbee
Battery life time	Several hours	Several days	Several years
Coverage	100m	10m	10m to several km
Nodes number	32	7	65000
Security	SSID	64 bit, 128 bit	128bit AES
Complexity	high	complex	simple
Data rate	11mbps	1mbps	250kbps
Time for network communication	3sec	10sec	30msec
Extension	Roaming enable	no	yes

II. LITERATURE REVIEW

ZigBee is wireless technology designed to address the unique needs of low-cost, low-power wireless sensor and control networks [1].

Since ZigBee can be used almost anywhere, is easy to implement and needs little power to operate, the opportunity for growth into new markets, as well as innovation in existing markets, is limitless. The system dedicated is to alert and inform the driver whenever the vehicle approaches a preset waypoint on the road. A ZigBee-based unit is installed at each waypoint, broadcasting relevant information to corresponding ZigBee units embedded in approaching vehicles.

Such a system significantly reduces the reliance on human vision and on-road lighting on human vision and on-road lighting conditions.



III. BLOCK DIAGRAM

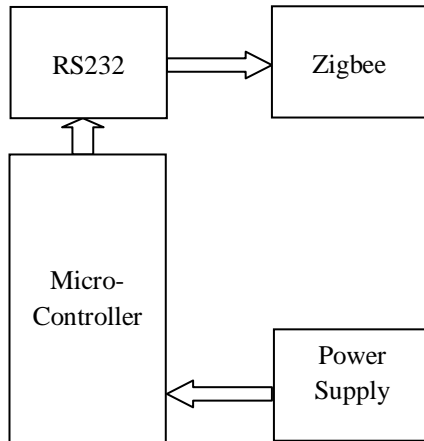

Fig.1. Transmitter Module

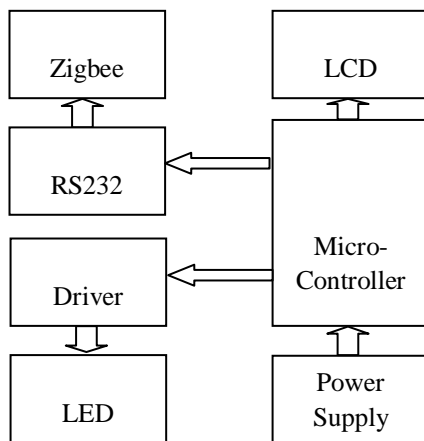

Fig.2. Receiver Module

Hardware required are:-

- 1) Zigbee
- 2) Microcontroller
- 3) RS232 Zigbee
- 4) RS232
- 5) LCD
- 6) LED
- 7) Power supply

There are two units named as waypoint unit(transmitter) and car unit(receiver). Waypoint node is placed at each preset point at the road infrastructure and car unit is placed at each car. Every car will have its id. Whenever the car will be arriving near the preset point the waypoint node will provide the information to the car through the car unit. Here the zigbee works as the sensor and provides the message through the microcontroller. Microcontroller works as the message provider. Here the system works for sign indicaton and to get communicate with the roadside infrastructure. It provides comfort at night driving and human vision.

IV. PROPOSED SYSTEM

A portable unit is placed inside the vehicles and it communicates with the system at all times. To overcome the existing system which is based upon radar, GPS and other sensor network problems, we introduce zigbee network.

Here we can place these portable unit in the bike also instead of car. So these unit using zigbee can be used in both.

V. ADVANTAGES

- 1) Low power consumption.
- 2) Long battery life.
- 3) Low cost.
- 4) Reliable and self healing.
- 5) Easy to implement.
- 6) Provides security.
- 7) Flexible.

VI. CONCLUSION

In this paper we discussed the importance of an safe driving assistance with roadside communication using zigbee and how it can help us improve safety standards on the road. The solution can significantly reduce the risk to drivers and make better traffic management and also comfort for human vision. Our Safe Driving Assistance system provides a very cost-effective alternative to more expensive systems like GPS, which provide navigation but do not have any fore-warning capabilities.

REFERENCES

- [1] Sourabh Pawade, Shraddha Shah, Prof. Dhanashree Tijare, " Zigbee Based Intelligent Driver Assistance System"/ International Journal of Engineering Research and Applications (IJERA) ISSN: 2248-9622 www.ijera.com Vol. 3, Issue 2, March -April 2013, pp.1463-1468 1463
- [2] Vaibhav P Choudhari, J M Bhattad, Gaytri Bhojar , "Review Of IEEE 802.15.4 For Intelligent Transport System Application" ,International Journal of Scientific Engineering and Technology (ISSN : 2277-1581) Volume No.2, Issue No.10, pp : 1038-1043 1 Oct. 2013
- [3] Won-Suk Jang, Miroslaw J. Skibniewski , "WIRELESS NETWORK-BASED TRACKING AND MONITORING" , Department of Civil and Environmental Engineering, University of Maryland, College Park, USA
- [4] Ioannou, P.A.; Chien, C.C. "Autonomous Intelligent Cruise Control". IEEE Trans. Veh. Technol. **1993**, 42, 657-67
- [5] B.Amutha , M.Ponnaivaikko, " Location Update Accuracy in Human Tracking (IJSIS)" International Journal of Computer Science and Information Security, Vol. 6, No. 2, 2009
- [6] Suhas Chakravarty, — "Low-Cost Driver Assistance Using ZigBee!" ,inBeyondBits2009.
- [7] T.shyam ramnath, " Integrated Drunken Driving Prevention System",in world Academy of science-engineering and Techonlgy aug04-2010,page no.830
- [8] Shorey.R Ananda.A.,chan,M and Ooi.W.(2006)"Mobile, Wireless and Sensor Network" ,john Wiley & Sons, Canada.